

OPERATING MANUAL Up Lift 5 HD200

Operating Manual UP Lift 5 HD200 (Translation of the original manual)



UP LIFT 5 HD200 NR: _____

OPERATING MANUAL Up Lift 5 HD200

Contents

| | |
|---|----|
| Introduction | 5 |
| 1. GENERAL INFORMATION | 5 |
| 1.1. Manufacturer: | 5 |
| 1.2. Marking of the lift - a sample data plate..... | 5 |
| 1.3. Definitions | 6 |
| 1.4. Safety symbols used in the manual | 6 |
| 1.5. National requirements | 6 |
| 1.6. Declaration of Conformity – template..... | 7 |
| 1.7. Intended use of the man lift..... | 8 |
| 1.8. Technical data..... | 8 |
| 2. CONSTRUCTION OF THE LIFT | 8 |
| 2.1. Drawing..... | 8 |
| 2.2. Base | 10 |
| 2.3. Power unit..... | 10 |
| 2.4. Control panel | 10 |
| 2.5. Electrical box..... | 10 |
| 3. OPERATING MANUAL | 10 |
| 3.1. Preparation..... | 11 |
| 3.1.1. Environmental control | 11 |
| 3.1.2. Installation of ballasts..... | 11 |
| 3.1.3. Moving the Up Lift 5 HD200..... | 12 |
| 3.1.4. Stabiliser feet..... | 12 |
| 3.2. Operation of the lift | 14 |
| 3.2.1. Control panel operation | 14 |
| 3.2.2. Completion of work..... | 15 |
| 3.2.3. Removal and reinstalation of batteries | 15 |
| 3.2.4. Charging the batteries..... | 15 |
| 3.2.5. Overload..... | 16 |
| 3.2.6. Emergency lowering..... | 16 |
| 4. RESIDUAL RISK..... | 17 |
| 5. SAFETY GUIDELINES..... | 18 |
| 5.1. Using the lift inconsistently with its intended use..... | 18 |
| 5.2. Additional rules | 18 |
| 6. STORAGE AND TRANSPORT | 19 |
| 7. MAINTENANCE | 19 |

OPERATING MANUAL Up Lift 5 HD200

| | | |
|--------|--|----|
| 7.1. | Definitions | 19 |
| 7.2. | Maintenance and inspection schedule | 19 |
| 7.3. | Maintenance inspections - additional remarks | 19 |
| 7.4. | Ad hoc and service inspections. | 19 |
| 7.5. | Guidelines for inspections | 20 |
| 7.6. | How to replace parts..... | 20 |
| 7.6.1. | Spare parts list | 21 |
| 8. | INSTRUCTIONS FOR THE CHARGER | 25 |
| 8.1. | Charger specifications | 25 |
| 9. | GUARANTEE POLICY | 26 |
| 10. | CONTROL CIRCUIT DIAGRAM | 27 |
| 11. | OPERATION BOOK – SAMPLE | 28 |
| 11.1. | Up Lift 5 HD200 data:..... | 28 |
| 11.2. | Inspection book | 29 |
| 12. | COMPLAINT FORM | 31 |

OPERATING MANUAL Up Lift 5 HD200



OPERATING MANUAL Up Lift 5 HD200

Introduction

We are pleased that you have chosen UP Lift 5 HD200 man lift, the sole manufacturer of which is Lockhard Sp. z o.o.

This operating manual is considered to be an integral part of the UP Lift 5 HD200 lift. It contains the necessary information on the assembly, correct operation and disassembly of the machine, as well as HSE and maintenance information. A complete and legible operating manual must be kept at hand in a printed version on the lift.

In order to avoid unnecessary damage and hazards, the operator/user is required to read, understand and follow this operating manual with understanding and observe it.

In addition to this operating manual, the general regulations applicable in a given country concerning environmental protection, occupational health and safety and accident prevention must be observed.



LOCKHARD Sp. z o. o. is not responsible for direct or indirect damage resulting from failure to comply with this OPERATING MANUAL at the stage of delivery, assembly and use for UP Lift 5 HD200.

1. GENERAL INFORMATION

1.1. Manufacturer:

LOCKHARD Sp. z o.o.
ul. Ostrowska 74a
63-410 Gorzyce Wielkie
Tel. +48 502 242 474
e-mail: office@lockhard.eu

1.2. Marking of the lift - a sample data plate

| | | |
|---|---|---|
|  | Lockhard Sp. z o.o. ul.Ostrowska 74a 63-410 Gorzyce Wielkie POLAND |  |
| Product: | Up Lift 5 200 HD According with Standard PN-EN 280 | |
| Year of manufacture: | 2023 | Weight w/o ballast : 140 kg + ballast 60 kg |
| Safe working load: | 200 kg | Voltage: 2x12V DC |
| Platform dimensions: | 48x69 cm | Electric actuator 2xLA36-1700N |
| Lifting height: | 2.93 m | Serial number: 2UP5023xxx |

OPERATING MANUAL Up Lift 5 HD200

1.3. Definitions

Lift Up Lift 5 HD200 - is a mobile machine designed to lift people and loads in a basket. The device consists of a base, a moving mast, a basket with controls and a drive system.

Basket - a part of the lift with automatically closed gates, used to move the operator to the desired working position.

Operator - a person, adequately trained and authorised to operate lifting devices.

Rated safe working load - the maximum permissible mass to be lifted in the basket. Rated safe working load includes the weight of the operator, tools and materials placed in the basket.

1.4. Safety symbols used in the manual

The following symbols are used to draw attention to points in this manual that contain important information or indicate hazards. When reading the operating manual, pay special attention to the points marked with these symbols.

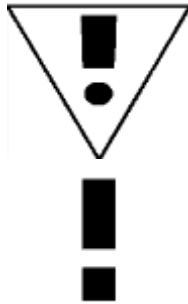

Danger

This symbol indicates a direct threat to life and health. Failure to comply with the rules means danger to life or risk of serious injury and significant material damage.

Note

Indicates a warning against possible damage to the lift or other property in the event of improper performance of the indicated activity.

1.5. National requirements

In addition to this operating manual, read the applicable national and local statutory regulations and other regulations in force concerning work safety. The above requirements also applies to the rules of working at heights and environmental protection in a given country.

In Poland, Up Lift 5 HD200 is a machine qualified as handling equipment and the operator must have the appropriate qualifications to operate handling equipment of type IP or IIP confirmed by the Office of Technical Inspection.

Legal basis:

Regulation of the Council of Ministers of 7.12.2012 on the types of technical devices subject to technical inspection (Polish Journal of Laws of 2012, No. 0, item 1468), issued on the basis of Article 5 paragraph 2 of the Act on technical inspection.

Pursuant to the Polish Regulation of the Ministry of Economy, Labour and Social Policy of 29.10.2003 about technical conditions and technical inspection in the scope of operation of certain handling equipment. In accordance with Section 25.1, Point 6, after changing the location of the UTB, no ad-hoc operational inspections of the device with single-phase power supply are required.

OPERATING MANUAL Up Lift 5 HD200

1.6. Declaration of Conformity

EU DECLARATION OF CONFORMITY

Manufacturer: **LOCKHARD Sp. z o. o.**
ul. Ostrowska 74A
63-410 Gorzyce Wielkie
office@lockhard.eu
www.lockhard.eu

Product: **UP Lift 5 HD200**

serial number:

We hereby declare that the product specified above complies with the essential health and safety requirements of EN 280+A1:2015-11 and EN 60204-1:2018-12.

The product is marked with the mark: **CE**

Storage location of technical documentation:

LOCKHARD Sp. z o.o.
ul. Ostrowska 74a
63-410 Gorzyce Wielkie

Technical Director:
Łukasz Leonhard

Gorzyce Wielkie, date

.....

OPERATING MANUAL Up Lift 5 HD200

1.7. Intended use of the man lift

Up Lift 5 HD200 is intended only for vertical lifting of people to work position where they work from the basket, assuming that these people enter and leave the basket in its lower position.

1.8. Technical data

| | |
|----------------------------------|-----------------------------------|
| Maximum load in the basket | 200 kg (1 person + tools) |
| External dimensions (WxLxH) | 680 x 1100 x 1980 mm |
| Working surface dimensions (WxL) | 480 x 690 mm |
| Maximum lifting speed | 10 m/min. (at full battery power) |
| Maximum lifting height | 2,93 m |
| The weight of the lift | 140 kg + 60 kg ballast |
| Supply voltage | 12 V DC |
| Battery capacity | 39 Ah |
| Battery voltage | 12 V |
| Temperature of use | -15°C to +40°C |
| Noise level | Does not exceed 70 dB |

2. CONSTRUCTION OF THE LIFT

2.1. Drawing

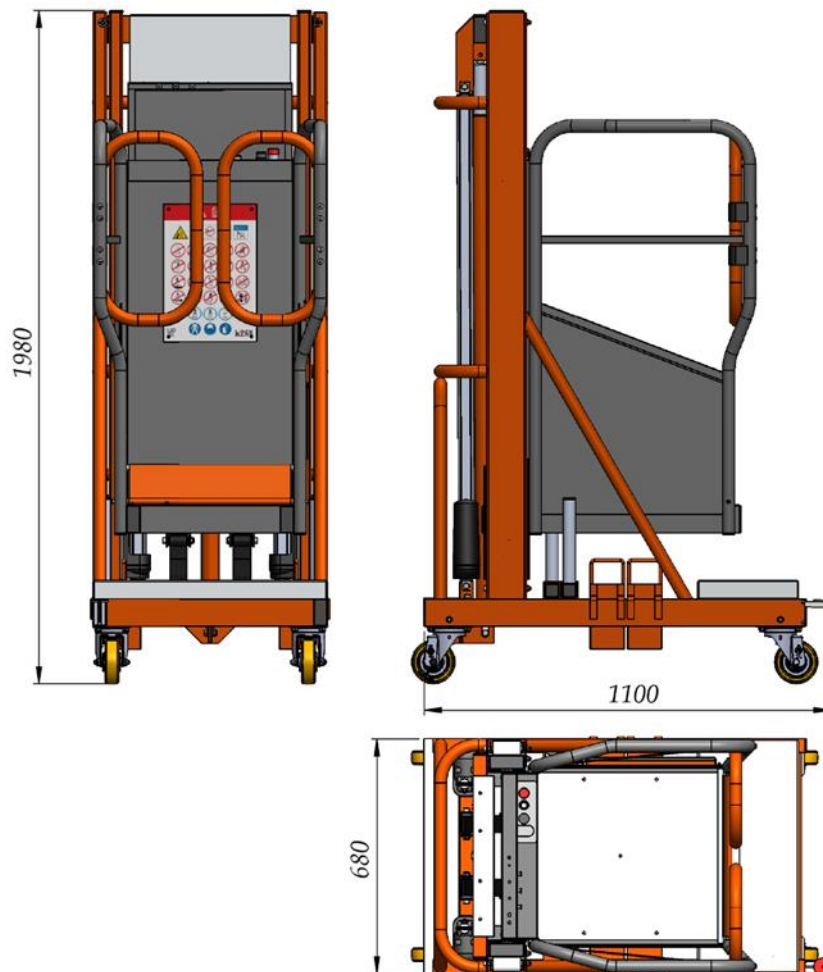

OPERATING MANUAL Up Lift 5 HD200

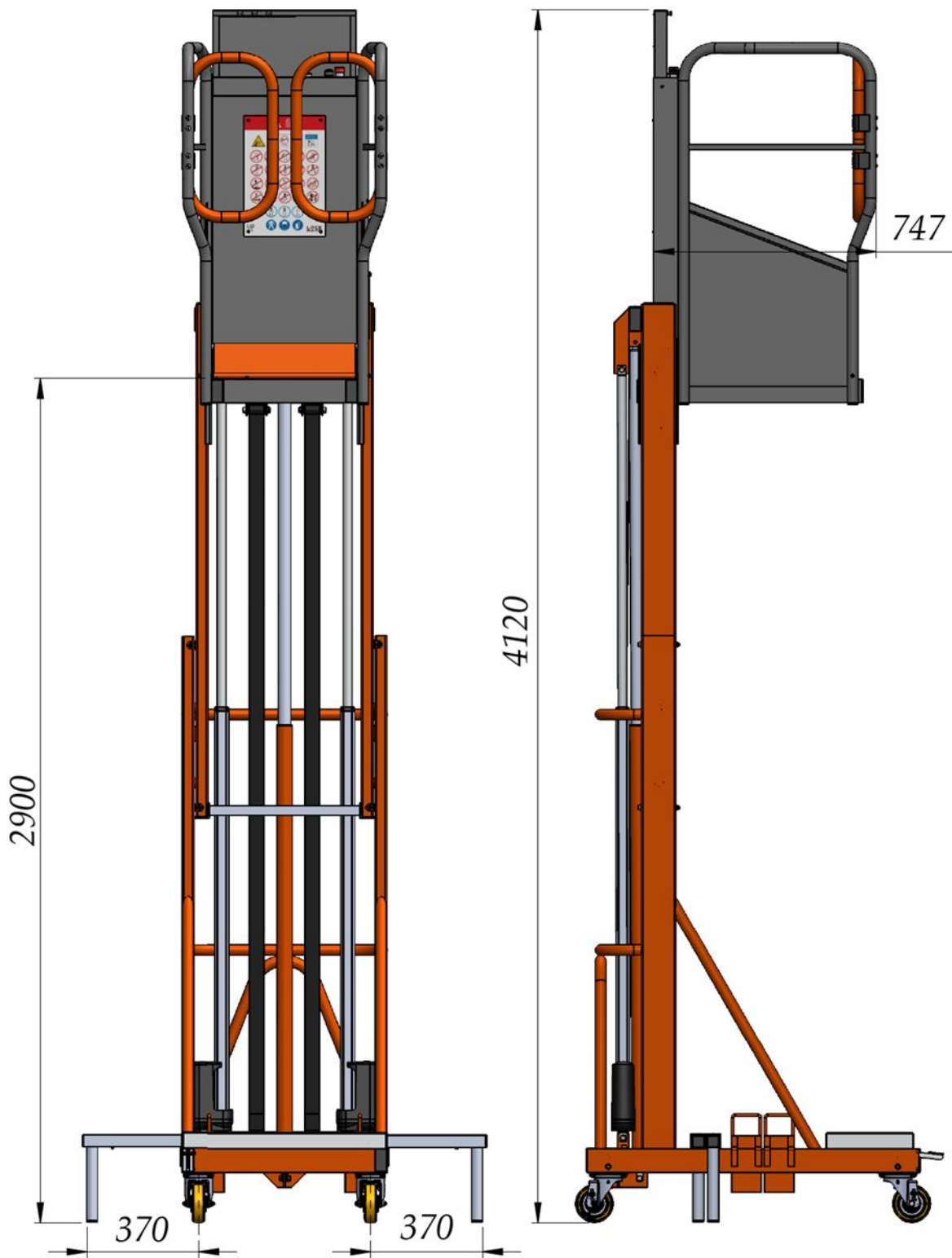

OPERATING MANUAL Up Lift 5 HD200

2.2. Base

The base with the load-bearing structure of the lift is made of welded steel hollow sections. The lift is moved by wheels with a foot brake. A 60 kg ballast and side stabilizers are used to ensure the lift's stability.

2.3. Power unit

Up Lift 5 HD200 basket is lifted by means of 2 electric actuators, which are permanently attached to the support frame of the base on one side and to the movable mast on the other side. The LA36 electric actuators are assisted by gas springs. The basket is lifted through a mast and system of belt slings.

2.4. Control panel

The control panel is located in the basket. There is a key switch on the panel (Fig. 1/2) and three buttons - a red emergency stop button (Fig. 1/1) and two buttons used to control movements (Fig. 1/3).



Figure 1. Control panel

2.5. Electrical box

At the base of the lift an electric box is located. Access to the box is possible after lifting the basket. The box contains the following items:

- emergency lowering button (Fig. 3/2);
- two 12 V/39 Ah batteries (Fig. 3/1);
- battery charger 110 V/230 V AC → 12 V DC/10 A (Fig. 3/5);
- 110 V/230 V AC cable with a plug (Fig. 3/3),
- XT60 connector (Fig. 3/4).



Figure 2. Emergency button



Figure 3. Electrical box

3. OPERATING MANUAL

The lift may only be operated by a properly trained and authorized operator who has read and understood these instructions and complies with the regulations on the proper use of the lifts in the user's country.

OPERATING MANUAL Up Lift 5 HD200



The user is responsible for the safe installation and operation of the UP Lift 5 HD200.

3.1. Preparation

Before starting operation, the lift must be checked for technical condition and possible defects. It is necessary to inspect the supporting structure, belts and the power unit. If any faults are detected, do not use the lift. Make sure that all control and protection devices are ready for operation and check the voltage on the digital display. If the voltage is lower than 10.5 V, charge the batteries.

3.1.1. Environmental control

In the area where the lift is to be operated, the surroundings should be checked for possible hazards, e.g. For electrical cables, ruins, rubble, excavations, mobile cranes, pedestrian traffic, vehicle or machinery traffic, etc. in the vicinity of the lift. Gradient in the area should not exceed 0.5°. If there is a risk of contact of the lift with power lines, voltage in the lines should be cut off. The work position where the lift is operated must be protected against access by unauthorised persons.

3.1.2. Installation of ballasts

In order to use the man lift properly and safely, ballasts on the base must be installed (Fig. 4). Properly placed ballasts should be secured with a bolted plate. The wrench needed to tighten the bolts is in the junction box. The total weight of the ballast is **60 kg** (4x 15 kg/33 lbs). When the work is finished, it is not necessary to remove the ballasts.



Figure 4. Ballast installation



IMPORTANT!
Ballasts must be fitted always when the lift is operated!

OPERATING MANUAL Up Lift 5 HD200

3.1.3. Moving the Up Lift 5 HD200

The lift should be pushed manually on the smooth, horizontal, solid and free of obstacles ground. Exercise extreme caution when moving the lift. The lift can be moved with the ballasts attached. After reaching the target place of work, lock the wheels with the foot brake - the wheels can be locked by pressing the foot lock (Fig. 5). To unlock the wheels, lift the wheel lock with your foot (Fig. 6).



*Figure 5. Wheel lock
Press the pedal to lock*



*Figure 6. Unlocking the wheels
Release the pedal to unlock the wheels*

A spirit level is installed on the base to control the horizontal position of the lift. (Fig. 7).



Figure 7. Spirit level

3.1.4. Stabiliser feet

To ensure safe operation of Up Lift 5 HD200, it is absolutely necessary to unfold the side stabiliser feet as described below:

- Press in the locking pin (Fig. 8 and 9) and pull out the feet from the socket (Fig. 10).
- rotate the stabiliser feet 180°
- insert the rotated stabiliser feet into the socket (Fig. 11 and 12) until it locks on the hole (Fig. 13).

OPERATING MANUAL Up Lift 5 HD200



Figure 8. Locking pin



Figure 9. Pressed locking pin

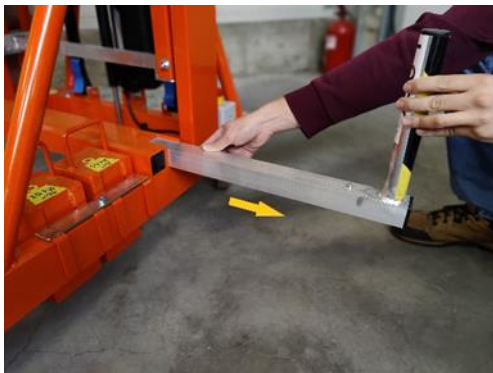

Figure 10. Pulling out the feet from the socket



Figure 11. Inserting the rotated stabiliser feet

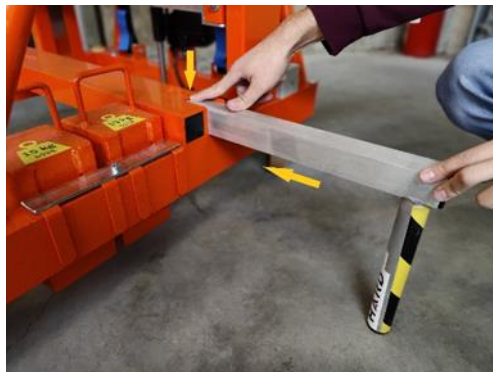

Figure 12. Inserting the rotated stabiliser feet



Figure 13. Locked locking pin

- perform the above steps for both feet.



Figure 14. Unfolded the side stabiliser feet

OPERATING MANUAL Up Lift 5 HD200



IMPORTANT!
**Stabilisers must be fitted every time
the lift is operated!**

- using the lift at a distance of less than 30 cm from the wall is allowed after fitting the stabiliser feet on one side (Fig. 15).



Figure 15. One-sided unfolding the stabiliser feet



IMPORTANT!
**It is forbidden to use Up Lift 5 HD200 without
properly installed ballasts and stabilisers**

3.2. Operation of the lift

The lift can be operated by one person, the control position is in the basket and the operator may enter or leave the basket only when it is lowered.

3.2.1. Control panel operation

- make sure the emergency stop buttons are not activated.
- turn the key to "ON" position (Fig. 1/2).
- control the basket movement using the "UP" or "DOWN" buttons marked with arrows (Fig. 1/3). In order to move the basket up and down, the button must be kept pressed.



**During lifting or lowering of the basket, operator and materials
must stay within the outline of the basket floor.**

If any hazards occur, stop the basket movement with the emergency stop buttons (Fig. 1/1 and Fig. 2) - after pressing the red button, the lift stops. The button must be turned to reactivate the power unit.

The up/down button cover protects the button against contamination. Replace the cover if damaged!

OPERATING MANUAL Up Lift 5 HD200

3.2.2. Completion of work

After completing the work, it is necessary to:

- lower the basket to the lowest position;
- turn the key in the main switch (Fig. 1/2) to "OFF" position, remove the key from the main switch to prevent unauthorised persons from using the lift;
- step out of the basket,
- fold the stabiliser feet;
- leave the lift in a safe place,
- lock the wheels with the brake,
- connect the battery for charging.

3.2.3. Removal and reinstalation of batteries

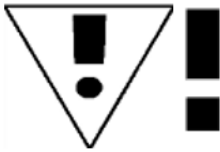

Make sure that the basket is in a position that allows the battery cover to be opened and that no people or material are present in the immediate vicinity.

Up Lift 5 HD200 is delivered with the batteries installed. During operation, however, there may be a need to remove and reinstall them:

- raise the basket to a height that allows the electric box cover to be opened - approx. 40 cm;
- open the cover;
- disconnect the battery by removing the XT60 connector (Fig. 16);
- remove the batteries from the box;
- close the cover;
- use the clamp to secure the cover against unintentional opening.



Figure 16. XT60 connector

To reinstall the battery:

- Make sure that the basket is at the right height,
- Put the battery in the box,
- Connect the batteries by connecting the XT60 connector (Fig. 16).

3.2.4. Charging the batteries

To charge the battery:

- connect the wire to the electric box;
- connect the cable to the mains supply 110/230 VAC;
- extension cords can be used for this connection according to EN IEC 61316:2021;
- while charging, the indicator lamp on the charger lights up red (Fig. 17/1). The indicator lamp will turn green when the battery is fully charged (Fig. 17/2);
- Once the battery is charged, disconnect the cable from the mains and the electrical box;



Figure 17. Battery charger

More information on the charger is given in Chapter 9.

OPERATING MANUAL Up Lift 5 HD200

In the event of a longer period of storage of the battery, the lift should be charged at least once a month for at least 12 hours.

3.2.5. Overload

Up Lift 5 HD200 is equipped with a system preventing the basket from being overloaded. If the basket cannot move upwards, it means that the basket has been overloaded and the weight should be reduced. Overload is signalled by an acoustic signal. In the event of severe overload, the fuse in the switch box may need to be replaced.

3.2.6. Emergency lowering

If the operator cannot lower the basket due to a failure of the control system or indisposition of the operator, emergency lowering of the basket can be activated. Up Lift 5 HD200 is equipped with two emergency lowering systems, the operation of which requires the intervention of an outside person who will be able to bring the basket to its lower position by means of:

- a) **electric emergency lowering system** - the emergency exit button is located under the cover of the electric box (Fig. 18). To lower the basket, press and hold the button. The button will not work if one of the Emergency Stop buttons is activated. Use of the electric lowering system in situations other than emergency situations and simultaneous use of the emergency lowering system with the main control system is forbidden and may lead to mechanical failure of the lift.



Figure 18. Electric lowering system



Figure 19. Mechanical lowering system

- b) **emergency lowering system** - with the bolts at the bottom of the actuators (Fig. 19). To lower mechanically, remove the cover and turn the bolts with a 6 mm Allen key. Turn both bolts evenly.

If the basket is blocked in the supporting structure, do not take any actions to restart the lift. Supervisors should decide on how to safely evacuate the operator from the bin.

In the event of a mechanical or electrical failure, please contact an authorized service technician of Lockhard Sp. z o.o.



Always follow the safety rules in this manual.

OPERATING MANUAL Up Lift 5 HD200

4. RESIDUAL RISK

Table 1. Potential dangers of improper use of the Up Lift 5 HD200.

| Danger! | Risk of injury |
|--|---|
| Risk of crushing due to lack of space | There is a risk of crushing if unauthorised persons are under the lowering basket. The risk arises in the event of breaking the ban on access to the basket. |
| Risk of crushing and abrasion of the skin | Risk of injury caused by extending a limb beyond the basket floor outline and leaning out during the vertical movement of the basket. |
| Lack of personal protective equipment | If personal protective equipment is not used, bodily injuries may occur, e.g. abrasions, cuts. |
| Human errors | Human errors may occur if the operating manual is not followed or due to the lack of proper training, which may result in loss of life or health, damage to the machine and all related costs. |
| Assembly errors | Assembly errors may occur if the assembly instructions are not followed, which may result in loss of life or health, damage to the machine and improper functioning of the machine. |
| Falling or thrown objects | During working in a basket, the employee is obliged to secure the materials stored in it. |
| Loss of stability/tipping over | Failure to follow the operating manual may result in loss of stability and overturning of the machine, which may result in damage to the machine, personal injury or death. |
| Slipping, tripping or falling people | The risk of slipping may occur in the event of poor maintenance of the basket and when the floor surface is slippery due to dirt. A tripping hazard can occur if the materials are not positioned correctly in the basket. |
| No maintenance | May result in a complete failure, which can cause injury to the operator, loss of health, damage to the environment and property. |
| Operation by an unauthorised person | Risk of injury may occur if an unauthorised and untrained person is in the basket or in its immediate vicinity. |
| Overload may result in overturning | When the basket is overloaded, stability can be lost. |
| Caused by difficult assembly/use/maintenance conditions. Use of inappropriate parts. | In the case of difficult conditions for assembly, disassembly, use and maintenance, human errors may occur, e.g. incorrect assembly, incorrect selection of parts, poor maintenance, too much hurry in the performed works. |

OPERATING MANUAL Up Lift 5 HD200

Instructions for recognition and rectification of failure and restart.

Table 2. Probable causes of failures of Up Lift 5 HD200 and remedies

| Failure | Probable cause | Remedies |
|--|---------------------------------------|--|
| Stopping the basket while it is moving | Overloaded basket (burned fuse) | Check the basket load, reduce load, replace fuse. |
| | Battery discharged | Drive to the lower position, replace or recharge the battery |
| | Contamination in the "UP-DOWN" button | Replace the button, blow out the buttons with compressed air |
| | Electrical actuator cable damaged | Fix the cable |
| | Microcomputer failure | Replace the microcomputer |

5. SAFETY GUIDELINES

5.1. Using the lift inconsistently with its intended use

When using UP Lift 5 HD200 man lift, it is forbidden to:

- Lifting more than one person in the basket;
- Moving the lift with operator in the basket;
- Moving the lift by towing with motor vehicles such as a car, forklift truck, tractor, etc.;
- Working in the basket near energised electrical appliances;
- Using lift in potentially explosive atmospheres;
- Using the lift as a crane;
- Using the lift as a supporting structure for hanging manual or mechanical winches;
- Standing on the basket's handrails or other elements out into the basket, e.g. a ladder, toolbox, etc.;
- Putting platforms between the lift and another structures (buildings, scaffolding, etc.);
- Resting objects against the structure of the lift during operation;
- Using a lift that is not serviced and has not passed the technical inspection;
- Simultaneous using the control panel and the emergency lowering system;
- Leaving and using a lift during rainfall and wind;
- Lowering the basket if there are bystanders or any obstacles under it;
- Horseplay while using Up Lift 5 HD200;
- Lowering a stuck basket;
- Using Up Lift 5 HD200 with open gate;
- Dragging wires, ropes etc. from the floor to the basket.
- Raising the basket when transporting the lift.

5.2. Additional rules

- Depending on the type of work performed with the lift, use personal protective equipment: work clothes and the equipment to protect your head, eyesight, hearing and limbs.
- When operating Up Lift 6 do not wear loose clothes, scarves, jewellery, etc.
- **UP Lift 5 HD200** is not equipped with its own lighting, therefore the user should ensure proper lighting of the workplace from an external light source.

OPERATING MANUAL Up Lift 5 HD200

6. STORAGE AND TRANSPORT

Up Lift 5 HD200 should be stored in rooms with paved floors, adequately protected against rain and snow. Avoid dust, grease or other contamination. The battery should be stored at a positive temperature in accordance with the operation and maintenance manual.

7. MAINTENANCE

7.1. Definitions

Maintenance man - a person duly authorised to carry out maintenance duties on the lifts in accordance with the regulations in force in the user's country. In Poland – a person authorised by the Office of Technical Inspection to maintain handling equipment in P. Category (Mobile Platforms).

Service technician - is a person who has been properly trained by the manufacturer of Up Lift 5 HD200. Periodic replacement of components or ad hoc repairs of the lift may be performed by the manufacturer's service or service units authorised by the manufacturer.

7.2. Maintenance and inspection schedule

Maintenance inspections should be performed every 90 days by an authorised operator. The environment in which the lift is operated and the frequency of use may affect the maintenance schedule.

List of inspection or maintenance activities:

1. Visual inspection of the superstructure;
2. Belts inspection;
3. Functional check
4. Cleaning, lubrication of mechanical parts;
5. Replacement of illegible stickers and instructions;
6. Checking the electrical system. Cables, connections and insulation
7. Battery connection check

7.3. Maintenance inspections - additional remarks

The purpose of the inspection is to check:

- The technical condition of the drive mechanisms, brake systems, load-bearing structure, in particular welded joints,
- The assembly of the belts, gas springs and the actuator. Operation of safety and emergency stop systems. Button operation.

The maintenance man is obliged to:

- Log the maintenance of the Up Lift 5 HD200 lift in the machine log book with the date and signature confirming the result of the inspection and the scope of the activities performed.
- In the event of irregularities, the maintenance man as the person responsible for the Up Lift 5 HD200 makes a decision about the need to take the lift out of service.

7.4. Ad hoc and service inspections.

Occasional inspections of the lift should be performed after a break in operation lasting longer than 2 weeks (when the lift is fully assembled but not in use). The operator is responsible for performing ad hoc inspections. The results of ad hoc inspections should be recorded in the Up Lift 5 HD200 log book by the persons performing the inspection.

OPERATING MANUAL Up Lift 5 HD200



Identified faults should be addressed right after inspection.

Annual inspection of the lift is to be carried out by a body authorised by the manufacturer.

7.5. Guidelines for inspections

In order to carry out an inspection, check the following:

- Basket, all suspension points, rollers, belts and screws;
- Side stabiliser feet;
- Handrails and gates (must close automatically);
- Wheels and wheel brakes;
- Technical condition of individual parts; pay attention to:
 - Cracks in the structure (especially in welded areas);
 - Distortions and fractures;
- Control panel:
 - Emergency stop button;
 - Operation of the buttons;
 - Key switch;
- Lifting belts - mechanical damage to the belts is unacceptable (must be replaced immediately).
- Stickers and information on the lift.
- Static test:
 - Place the nominal load in the basket - 120 kg. Raise the basket to a height of about 1m;
 - Measure the distance between the ground and the lower edge of the basket;
 - Leave the basket in this position for approx. 15 min.;
 - Measure the distance again after the required time;
 - Permissible lowering of the basket is - 5 mm.

7.6. How to replace parts











After a certain period of operation, the following parts must be replaced.

Table 3. Replacement of parts

| Part | Operating time |
|--|---|
| Electric actuator | 5 years or 18.5 thousand cycles at full load (25 000 at 80% load) |
| Carrying belts | 3 years |
| Wheels | 5 years or after 2000 operating hours |
| Rollers (tables 12-16, items 18, 19, 22) | 5 years or after 1000 operating hours |

OPERATING MANUAL Up Lift 5 HD200

7.6.1. Spare parts list

| Lp. | PICTURE | NAME | ARTICLE NO. | DIMENSIONS | WEIGHT |
|-----|---|-------------------------------|--------------|----------------------|---------|
| 1. |  | Electric actuator, 1700N | EA1700N | 20 x 10 x 160-280 cm | 13 kg |
| 2. |  | Electric actuator controller | MSCUp | | |
| 3. |  | 1500N gas spring (set of two) | GS1500N | 300 cm, Ø 50 mm | 8 kg |
| 4. |  | Basket | CUp | 65 x 70 x 119 cm | 12 kg |
| 5. |  | Gate (right+left) | DR | 35 x 60 x 10 cm | 3 kg |
| 6. |  | Stabiliser | UpSTAB1PART2 | 68 x 29 x 4 cm | 1 kg |
| 7. |  | Automatic side | AB | 47 (50.5) x 10 cm | 0.5 kg |
| 8. |  | Step clamp | CS | | |
| 9. |  | HD wheel Ø 125 mm | WHD | Ø 125 mm | 0.75 kg |
| 10. |  | Battery | BAT | 19.5 x 13 x 17.2 cm | 10.5 kg |
| 11. |  | Charger Up Lift 200 | ChRUp200 | | |







OPERATING MANUAL Up Lift 5 HD200

| | | | | | |
|-----|---|---|---------|--------------------|----------|
| 12. |  | Emergency switch electric box | UPELBEB | | |
| 13. |  | Ballast | BT | 20 x 15 x 17 cm | 15 kg |
| 14. | | Electrical box | UpELB | 8 x 15 x 25 cm | 1 kg |
| 15. |  | 91 mm roller | Rr91 | 91 x 25 mm | 0.1 kg |
| 16. |  | 30 mm roller for mast and basket | Rr30 | DN 30 x 22 mm | |
| 17. |  | Roll of 40mm mast | Rr40 | 40 x 80 mm | |
| 18. |  | XT60 connector | XT60 | | 0.006 kg |
| 19. |  | Parts for 2 belts | Pb | | |
| 20. |  | Belts (2 pieces) | BT | 0.3 x 5 x 306 cm | 1 kg |
| 21. |  | 80X40 plug | Pg80 | 80 x 40 x 22 mm | |
| 22. |  | DN 35 mm plug | Pg35 | DN 35 x 20.2 mm | |
| 23. |  | 100X40 plug | Pg100 | 100 x 40 x 24.5 mm | |
| 24. |  | 40 mm spirit level | SL40 | DN 40 mm | |
| 25. |  | Charger socket | ChS | | |

OPERATING MANUAL Up Lift 5 HD200

| | | | | | |
|-----|---|--|--------|-----------------|--|
| 26. |  | Power cord | WpUp | 5 m | |
| 27. |  | Cable for control panel | WrRCUp | 6 m | |
| 28. |  | Left door spring | SL | | |
| 29. |  | Spring for the right door | SR | | |
| 30. |  | Plastic top hinge for the door | GdT | | |
| 31. |  | Plastic bottom hinge for the door | GdB | | |
| 32. |  | HD pedal | PHd | 64 cm | |
| 33. |  | Cable for HD wheel | DHD | | |
| 34. |  | HD wheel shaft | PHd | | |
| 35. |  | Control panel box | CpC | 18 x 7.5 x 6 cm | |
| 36. |  | Up/Down button | Bud | | |
| 37. |  | Key button | Bk | | |
| 38. |  | Emergency stop | UPEB | | |
| 39. |  | Cover for the Up-Down button | CBud | | |
| 40. |  | Contactor for the Up/Down button | Cud | | |

OPERATING MANUAL Up Lift 5 HD200

| | | | | | |
|-----|---|--|--------------|-----------------|--|
| 41. |  | Contactor for the emergency button/Key switch | Cebk | | |
| 42. |  | Control panel | CP | 18 x 7.5 x 6 cm | |
| 43. |  | Main switch | MS | | |
| 44. |  | Main switch with cable | MSw | | |
| 45. |  | Charger belt | BC | | |
| 46. |  | Key | KEYUp | | |

OPERATING MANUAL Up Lift 5 HD200

8. INSTRUCTIONS FOR THE CHARGER

This manual contains important safety information related to using the ET4-0227 multi-purpose charger:

- In the event of a voltage drop, an acoustic signal will inform about the need to recharge the batteries.
- The charger is permanently installed in the box and properly connected to the batteries.
- The nominal charging current for 12 V batteries is 10 A.
- The charger is intended only for charging 12 V lead, AGM and gel batteries. Do not charge batteries of any other type.
- If the charger is disconnected or damaged due to a strong short circuit, immediately disconnect the charger from the battery.
- The necessary repairs should be carried out by qualified personnel. Improper installation may cause fire and/or short circuit.
- Before cleaning the housing, always disconnect the charger from the battery and unplug it from the mains.
- Follow the recommended battery charging procedures.
- The battery generates hydrogen and oxygen during charging. Such a combination creates an explosive mixture. Provide sufficient ventilation and avoid source of ignition such as sparks, smoking, etc.
- The liquid inside the batteries is highly corrosive. In case of contact with skin or eyes, rinse the area with clean water and seek medical attention immediately.
- Lead batteries store a lot of energy. A short circuit in the battery will cause the battery to try to release this energy immediately, which may lead to a fire or injury. Make sure that metal objects (or other conductive material) do not touch the + and - poles at the same time.

8.1. Charger specifications

| | |
|-------------------------------|--|
| Charger type: | 12 VDC, 10 A |
| Input voltage: | 115-260 VAC, 50 Hz |
| Output voltage: | 12 V |
| Capacity: | >75% |
| Charging voltage: | 14.4 V \pm 0.25 V or 13.6 V \pm 0.25 V |
| Charging current: | 10 A \pm 10% or 8.0 A \pm 10% or 4.0 A \pm 10% |
| Protective conductor current: | <5 mA |
| Fluctuations: | Max. 150 mV, 0.3 A |
| Air temperature: | - 20 °C - 40 °C/ -4 °F - 104 °F, performance is reduced at higher temperatures |
| BATTERY TYPES: | 12 V lead-acid batteries (WET, MF, AGM & VRLA) |
| Ingress protection: | IP65 |

OPERATING MANUAL Up Lift 5 HD200

9. GUARANTEE POLICY

UP Lift 5 HD200 is covered by a one-year manufacturer's guarantee.

The "General LOCKHARD Sp. z o. o. sales and delivery" rules apply.

Guarantee and statutory warranty claims for personal and material damage are excluded, if it occurred due to reasons such as:

- Using the Up Lift 5 HD200 inconsistently with the operating instructions.
- Incorrect installation, start-up, operation or insufficient servicing of the Up Lift 5 HD200.
- Using the UP Lift 5 HD200 with damaged, defective or incorrectly installed safety devices.
- Failure to follow the instructions given in the operating manual regarding transport, assembly, start-up, use, servicing, equipment and storage of the Up Lift 5 HD200.
- Making changes to the Up Lift 5 HD200 structure.
- Repair of faults by unauthorised persons.
- Damage caused by weather conditions.
- Damage caused by high external forces.
- Lack of annual inspection carried out by a service technician and lack of a sticker confirming this fact.
- Lack of service logbook with history of the lift as well as history of inspections and servicing carried out.

OPERATING MANUAL Up Lift 5 HD200

10. CONTROL CIRCUIT DIAGRAM

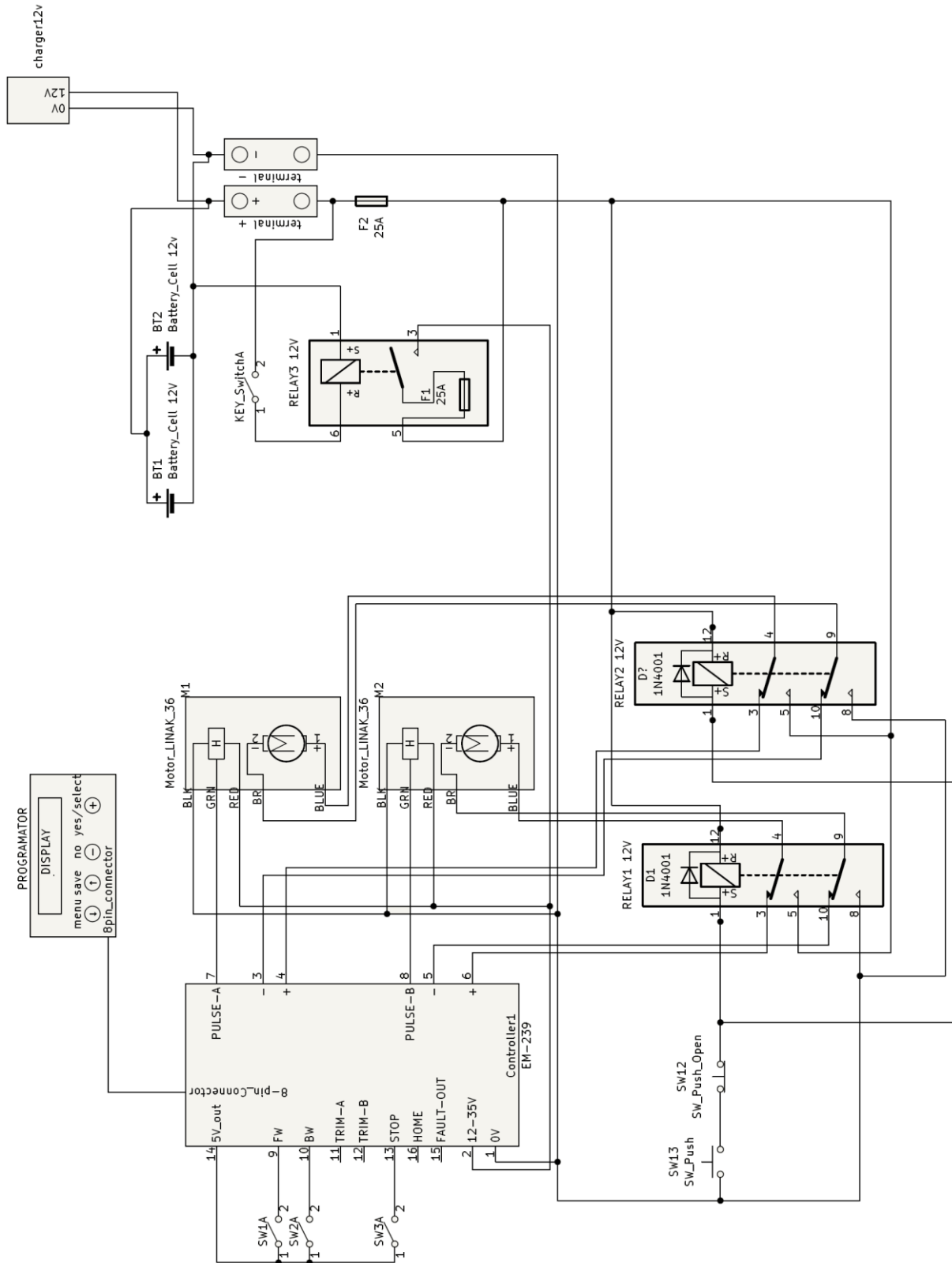

OPERATING MANUAL Up Lift 5 HD200

11. OPERATION BOOK – SAMPLE

In order to comply with the applicable legal regulations, an Operation book for the Elevator Up Lift 5 HD200 should be maintained. Please refer to country-specific regulations.

11.1. Up Lift 5 HD200 data:

Guarantee Card Number: _____

Product Name: _____

Serial Number: _____

Date of Manufacture: _____

Date of Sale: _____

Manufacturer: LOCKHARD Sp. z o.o

The "General LOCKHARD Sp. z o. o. sales and delivery" rules apply.

Supplier's stamp

Manufacturer's stamp

Name and Address of the Owner:

Name: _____

Addressee: _____

Operator: _____

OPERATING MANUAL Up Lift 5 HD200

11.2. Inspection book

Form - Inspection of Lift, Type:

Serial Number:

Inspection Number:

Number of Hours:

Date:

Conducted by:

Address:

Contact:

Work Performed:

Date of next Inspection:

Form - Inspection of Lift, Type:

Serial number:

Inspection Number:

Number of Hours:

Date:

Conducted by:

Address:

Contact:

Work Performed:

Date of next Inspection:

Form - Inspection of Lift, Type:

Serial Number:

Inspection Number:

Number of Hours:

Date:

Conducted by:

Address:

Contact:

Work Performed:

Date of next Inspection:

OPERATING MANUAL Up Lift 5 HD200

Form - Inspection of Lift, Type:

Serial Number:

Inspection Number:

Number of Hours:

Date:

Conducted by:

Address:

Contact:

Work Performed:

Date of next Inspection:

Form - Inspection of Lift, Type:

Serial number:

Inspection Number:

Number of Hours:

Date:

Conducted by:

Address:

Contact:

Work Performed:

Date of next Inspection:

Form - Inspection of Lift, Type:

Serial number:

Inspection Number:

Number of Hours:

Date:

Conducted by:

Address:

Contact:

Work Performed:

Date of next Inspection:

OPERATING MANUAL Up Lift 5 HD200

12. COMPLAINT FORM

Complaint

Owner: _____

Address: _____

Guarantee Card number: _____

Product Type and Serial Number: _____

Purchase Date: _____

Date of Detection of Defect / Hours Counter: _____

Short Description of the Defect:

Date and Place: _____ Signature: _____

Complaint

Owner: _____

Address: _____

Guarantee Card number: _____

Product Type and Serial Number: _____

Purchase Date: _____

Date of Detection of Defect / Hours Counter: _____

Short Description of the Defect:

Date and Place: _____ Signature: _____